



EAGLESKY CO., LTD.

BUTTERFLY VALVE-HANDLE 2"~8"



- Working pressure 2"~4" EPDM seat: 200PSI/73°F
- Working pressure 2"~8" : 150 PSI / 73°F
- Universal bolt holes suitable for ASTM, DIN and JIS systems
- Low flow loss and Lower operation torque
- Worm gear operators
- Electric actuators
- Pneumatic actuators (ISO 5211)
- Protection for over tightening of mating flange

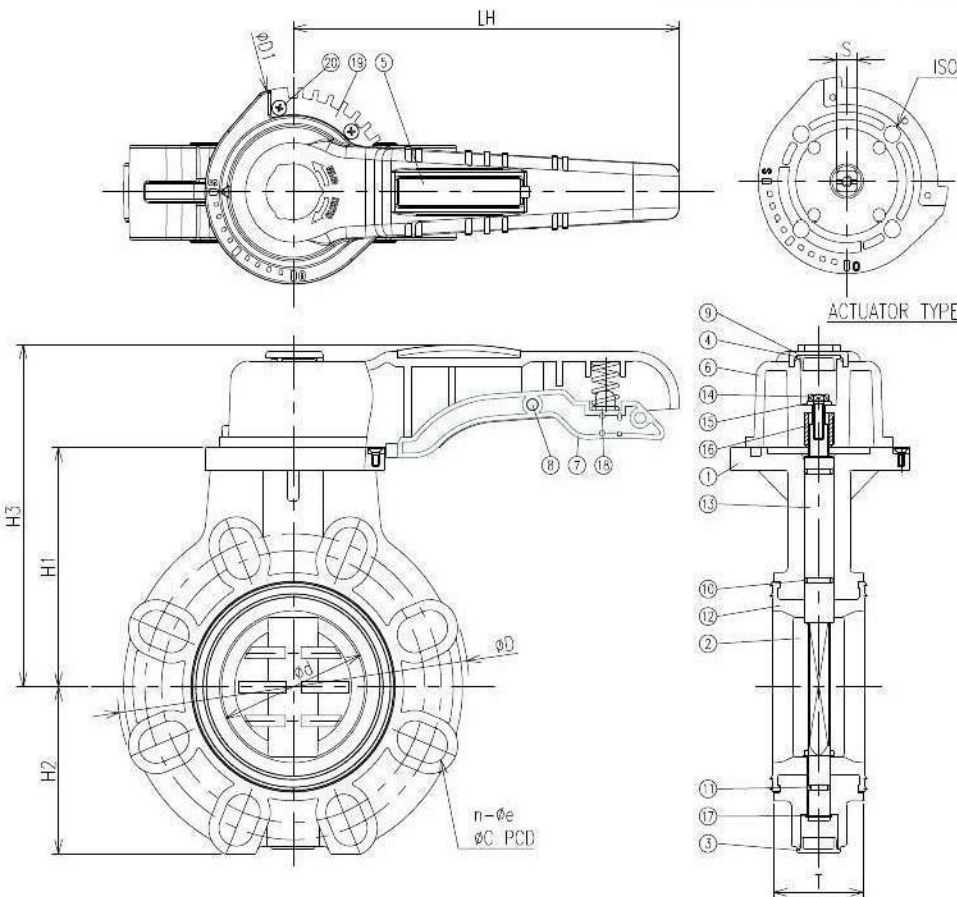

No	PARTS NAME	QTY	MATERIAL
1	BODY	1	PVC, CPVC
2	DISC	1	PVC, CPVC
3	BODY CAP	1	ABS
4	HANDLE CAP	1	ABS
5	HANDLE CAP	1	ABS
6	HANDLE	1	ABS
7	SMALL HANDLE	1	PPG
8	PIN	1	PPG
9	CLEAR CAP	1	AS
10	STEM O-RING	2	EPDM, FPM
11	STEM O-RING	1	EPDM, FPM
12	SEAT	1	EPDM, FPM
13	STEM	1	SUS410
14	BOLT	1	SUS304
15	WASHER	1	SUS304
16	INSERT	1	SUS304
17	C-RING	1	SUS304
18	SPRING	1	SUS304
19	GEAR	1	SUS304
20	BOLT	3	SUS304

SIZE	D	T	LH	H1	H2	H3	d	ANSI		DIN		JIS		D1	S	ISO 5211
								↑ C	n-↑ e	↑ C	n-↑ e	↑ C	n-↑ e			
2" (50mm)	156	43	210	91	72	158	57	120.7	4-19	125	4-18	120	4-19	110	11	F05 / F07
2-1/2" (65mm)	177	46	210	114	80	168	68	139.5	4-19	145	4-18	140	4-19	110	11	F05 / F07
3" (75mm)	191	49	210	126	88	180	78	152.4	4-19	160	8-18	150	8-19	110	11	F05 / F07
4" (100mm)	223	56	210	143	103	198	98	190.5	8-19	180	8-18	175	8-19	110	14	F07
5" (125mm)	253	64	280	170	117	234	122	215.9	8-19	210	8-18	210	8-23	156	17	F07 / F10
6" (150mm)	279	70	280	181	129	245	145	241.5	8-23	240	8-23	240	8-23	156	17	F07 / F10
8" (200mm)	337	71	330	218	162	287	195	298.5	8-23	295	8-23	290	12-23	156	22	F10

Technical Information

Item	Description	Size	Material		
			Body	Seat	O-ring
(1)	Butterfly Valve	2"(DN50)	PVC,CPVC	EPDM,FPM	EPDM,FPM
(2)	Butterfly Valve	2-1/2"(DN65)	PVC,CPVC	EPDM,FPM	EPDM,FPM
(3)	Butterfly Valve	3"(DN80)	PVC,CPVC	EPDM,FPM	EPDM,FPM
(4)	Butterfly Valve	4"(DN100)	PVC,CPVC	EPDM,FPM	EPDM,FPM
(5)	Butterfly Valve	5"(DN125)	PVC,CPVC	EPDM,FPM	EPDM,FPM
(6)	Butterfly Valve	6"(DN150)	PVC,CPVC	EPDM,FPM	EPDM,FPM
(7)	Butterfly Valve	8"(DN200)	PVC, ----	EPDM,FPM	EPDM,FPM

Size	Hydrostatic Testing		Seat and O-ring Tests		Torque N*m	Cv
	Burst pressure water(kg/cm ²) minimum	Long-term behaviour test water(kg/cm ²)	Seat valve close water kg/cm ²	O-ring valve open water kg/cm ²		
2"(DN50) EPDM	59	22	14	14	15	110
2-1/2"(DN65)EPDM	59	22	14	14	20	230
3"(DN80) EPDM	59	22	14	14	25	280
4"(DN100)EPDM	59	22	14	14	40	440
2"(DN50) FPM	42	22	11	11	15	110
2-1/2"(DN65) FPM	42	22	11	11	20	230
3"(DN80) FPM	42	22	11	11	25	280
4"(DN100) FPM	42	22	11	11	40	440
5"(DN125)	42	22	11	11	55	800
6"(DN150)	42	22	11	11	75	1000
8"(DN200)	42	22	11	11	110	2200

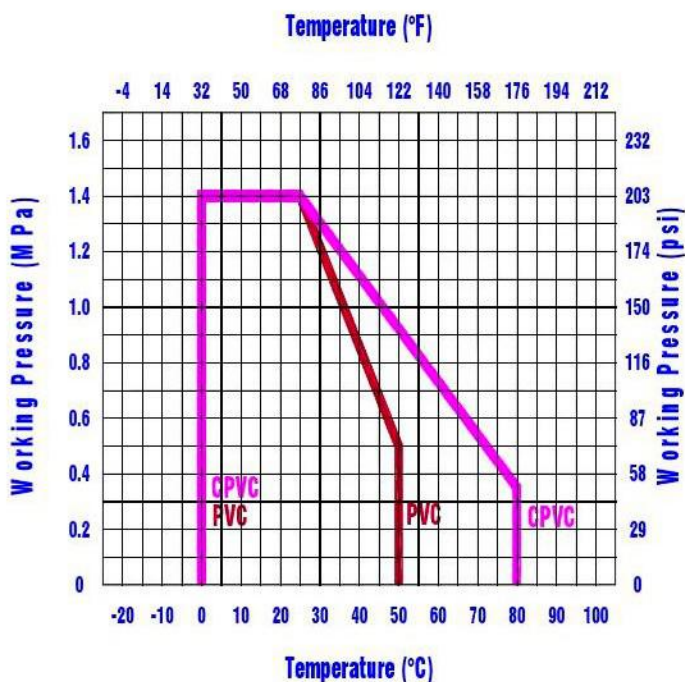

* 2"~4" EPDM seals

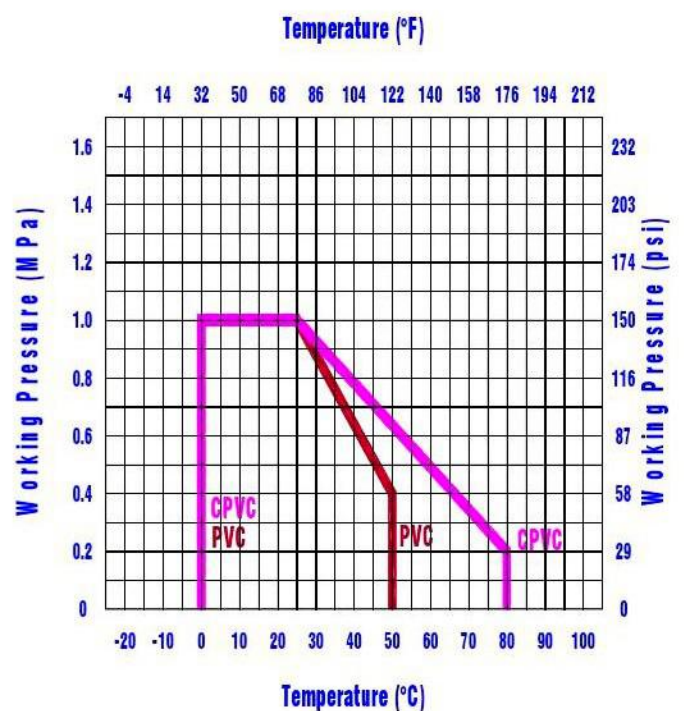

* 2" ~ 8"